

# Pedestrian stacker truck

## BT staxio

P-series

SPE120XR (Counterbalance)

Data sheet ver 3



**TOYOTA**

MATERIAL HANDLING

stronger together

# Pedestrian stacker

Specification for stacker trucks					SPE120XR (Counterbalance)	
Identification	1.1	Manufacturer			BT	
	1.2	Model			SPE120XR CB short	
	1.3	Drive			Electric	
	1.4	Operator type			Stand on / Pedestrian	
	1.5	Load capacity/rated load	Q	kg	500	
	1.6	Load centre	c	mm	600	
	1.8	Load distance, back of fork to bogie wheel centre	x	mm	-115	
	1.9	Wheelbase	y	mm	850	
	1.9	Wheelbase			1150	
Weight	2.1	Service weight with battery		kg	1845	
	2.2	Axle load, with load, drive/support arm wheel		kg	437/1908	
	2.3	Axle load, without load, drive/support arm wheel		kg	871/974	
Wheels	3.1	Drive/fork wheel			Vulkollan/Vulkollan	
	3.2	Wheel size, front		mm	Ø140	
	3.3	Wheel size, rear		mm	Ø250	
	3.4					
	3.5					
Dimensions	4.2	Height, mast lowered	$h_1$	mm	1822	
	4.3					
	4.4	Lift	$h_3$	mm	2450	
		Lift height	$h_{23}$	mm	2500	
	4.5	Height, mast extended	$h_4$	mm	2998	
	4.8	Stand height	$h_7$	mm	190	
	4.9	Height of tiller in drive position, highest lowest setting	$h_{14}$	mm	1201/1413 1101/1313	
	4.15	Height, fork lowered	$h_{13}$	mm	40	
	4.19	Overall length platform up/platform down	$l_1$	mm	2350/2800	
	4.20	Length to face of forks	$l_2$	mm	1200	
	4.21	Overall width	$b_1/b_2$	mm	850/900	
	4.22	Fork dimensions	$s/e/l$	mm	35/100/1150	
	4.25	Width over forks	$b_5$	mm	205 - 635	
	4.31	Ground clearance, with load, below mast	$m_1$	mm	30	
	4.32	Ground clearance, centre of wheelbase	$m_2$	mm	40	
4.33	Aisle width for pallets 1000 x 1200 mm crossways	$A_{st}$	mm	2641/3091		
4.34	Aisle width for pallets 800 x 1200 lengthways	$A_{st}$	mm	2749/3199		
4.35	Turning radius platform up/platform down	$W_a$	mm	1175/1625		
Performance data	5.1	Travel speed, with/without load		km/h	8,0/8,0	
	5.2	Lift speed, with/without load		m/s	0,29/0,36	
	5.3	Lowering speed, with/without load		m/s	0,45/0,45	
	5.8	Max. gradeability, with/without load <sup>1)</sup>		%	8/10	
	5.10	Service brake			Electromagnetic	
Electric motor	6.1	Drive motor rating (S2 60 min)		kW	1,8	
	6.2	Lift motor rating at (S3 15%)		kW	3,0	
	6.4	Battery voltage/nominal capacity $K_5$		V/Ah	24/500	
	6.5	Battery weight		kg	364	
	Others	8.1	Type of drive control			Variable AC
8.4		Sound level at the driver's ear according to EN 12 05		dB(A)	???	

<sup>1)</sup> Measured according to company standard

All data are based on table configuration. Other configurations may give other values.

Truck performance and dimensions are nominal and subject to tolerances.

BT products and specifications are subject to change without notice.

# Mast dimensions

# BT staxio

SPE125 (Counterbalance)			Duplex Tele	
h23	Lift height (h13 + h3)	mm	2500	
h3	Lift	mm	2450	
h1	Height, mast lowered	mm	1822	
h2	Free lift, ground to top of forks	mm	132	
h4	Height, mast extended	mm	2998	

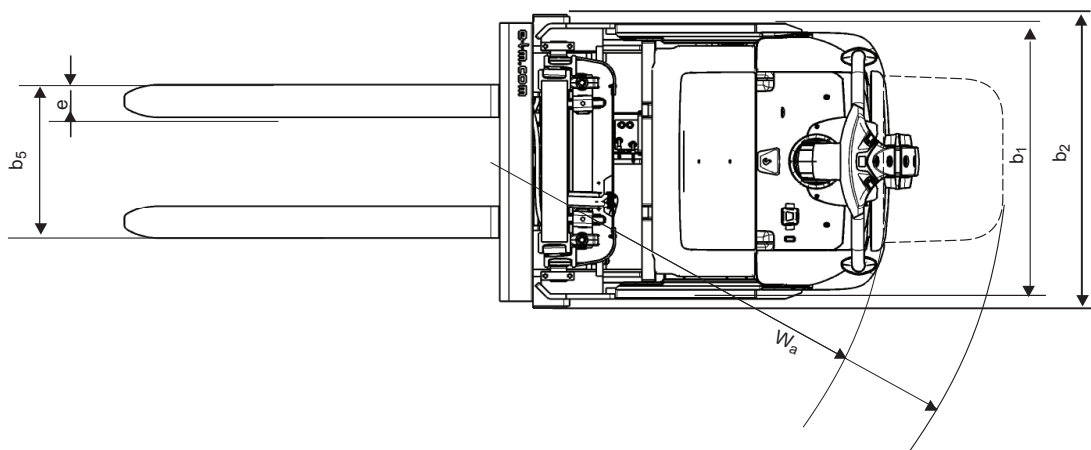
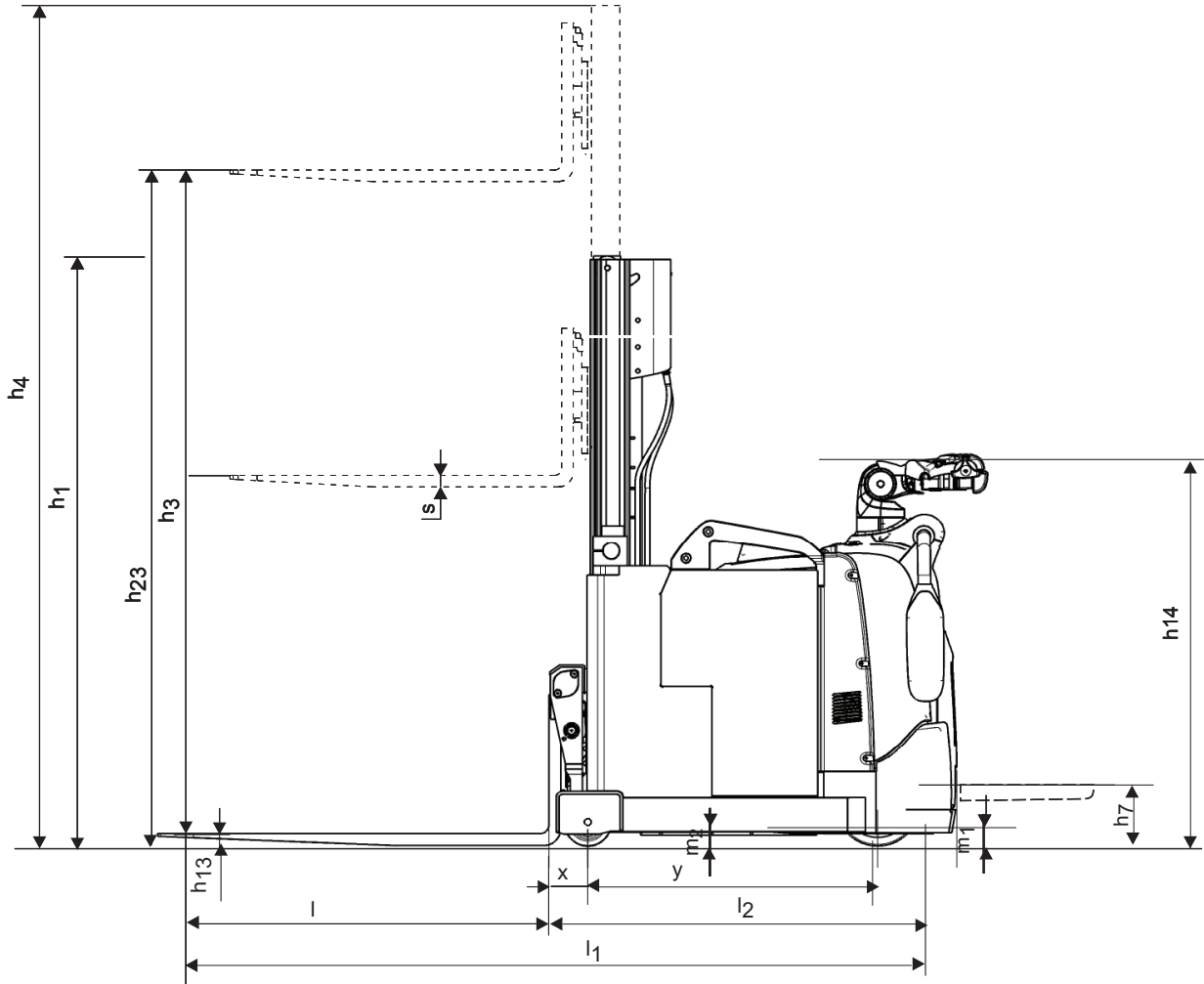

---

## Truck features:

- Power/Electronic steering
- Optimised Truck Performance
- Adjustable fork width
- Sensi-lift
- Height adjustable tiller arm
- One-touch foldable gates
- Click-2-Creep
- Electronic fingertip controls for all functions
- Access control
- Driver-adapted programmable performance
- Easy access for maintenance
- Sideshift and spreader attachment
- I\_Site (option)

